

# Athena SLB™

Manual MAP Sealing Machine, with or without MAP

Solutions For:



ATHENA uses Hefestus' SLB™ sealing head technology in a compact manual, easy to operate, low maintenance format.

ATHENA is our best selling model – used by small & medium packers and is a handy addition for large producers as well. Extremely compact and attractively priced, the ATHENA SLB™ is also ideal for R&D by academic, medical, agricultural and food packaging research.

MAP and seal process is **fully automatic**, ensuring best results every time.

Multiple sealing heads can be used for various trays, with no need for tools and with a very **short changeover time- less than 3 minutes !!**



The meat industry: fresh, frozen and processed meat delicacies.



Nuts



Fresh cuts: whole peeled or sliced fruits & vegetables.



Baked goods: cakes, cookies, chilled pizza, half-baked pastries etc..



Sandwiches & condiments.



Dairy products, personalized meals.



Fresh pasta.



Ready meals.

Extended Shelf Life - We Make It Happen



# Athena SLB™

Manual MAP Sealing Machine, with or without MAP ▶

Max Tray Dimensions : ▶

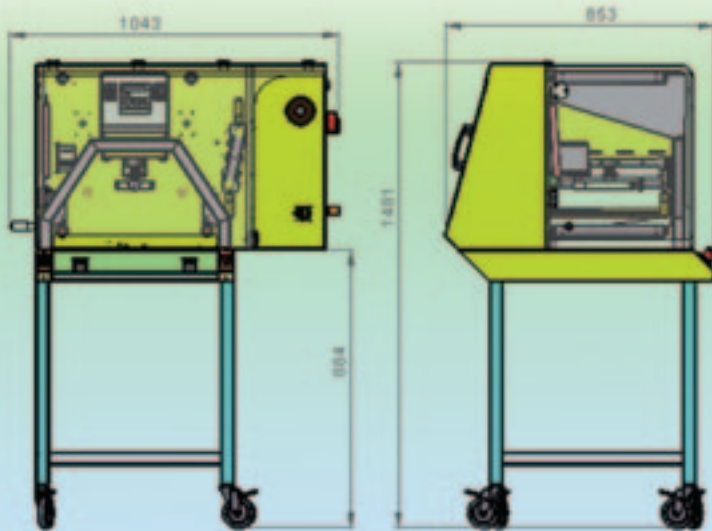

Machine dimensions	L 855 x W 1045 x H 1485 mm		
Machine weight	250 Kg		
Speed	7-20 trays/min		
Max. tray dimensions - for <b>single</b> sealing head	360 x 300 mm		
Max. tray dimensions - for <b>double</b> sealing head	300 x 170 mm		
Max. circumference film roll	280 mm		
Power Europe	1 phase	V 220	25 A W 1500
Power USA	2 phase	V220	25 A W 1500
Compressed Air	7 BAR	200 L/MIN	

Singel (tray) head

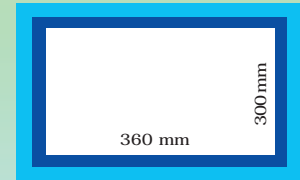

Double (tray) head

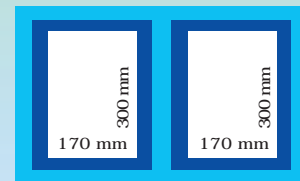

Triple (tray) head

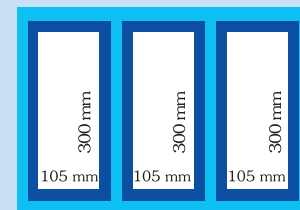

SLB™ – is Hefestus' registered patent for MAP without mechanical vacuum!

SLB™ – exclusively creating modified atmosphere without drawing mechanical vacuum at any stage, opens new markets to MAP.

Products packed with SLB™, cause no harm to texture or appearance of even the most delicate products while achieving best modified atmosphere results time after time.

SLB™ - Shelf Life Booster takes the MAP technology a giant step further.

Unlike all other MAP sealers – Hefestus' modified atmosphere is achieved in one fully automatic vacuum free SLB™ sealing head.

**Low oxygen – not to exceed 1% in package. Levels down to 0.01% upon request, remaining oxygen.**

Thanks to this novelty we offer a state of the art packaging solution to all products, even the most delicate "vacuum banned" goods, in extremely compact and affordable machines.

SLB™ extends product's shelf life without need for preservatives or freezing, enabling storage & delivery of goods at room temp or chilled.

Shaham St, P.O.B 3116, IND. PARK CAESAREA 38900 Tel. 972-4-6271835

e-mail: hefestus1@hefestus-slb.com www.hefestus-slb.com

